



**GL**

motor Alta Eficiencia



GL 45 X

Cod. **02030305** EAN **8422248077842**

- Panel de **Control Táctil** con temporizador de desconexión automática e indicador de limpieza de filtros
- 4 niveles de extracción, 3 + 1 **TURBO**
- Capacidad de extracción máxima - mínima (Reg.(UE) nº65/2014): **820m³/h** - 340m³/h
- **Nivel sonoro (Reg.(UE) nº65/2014): 50dB(A)**, máximo: 65dB(A)
- Motor BT3. Extra silencioso. Consumo máximo de energía **280W**
- **Iluminación de alta eficiencia mediante LEDs, regulables en intensidad**
- Sistema de fácil instalación
- Filtros lavables en lavavajillas
- Acabado en inox
- Presión max.: 450 Pa - Presión TURBO: 470 Pa
- Descarga 150/125 mm
- **Clase de eficiencia energética: A**

► **Accesorios (no incluidos)**

Filtro de Carbón Activo .....Cod. 02859398 / EAN 8422248075497.....  
 Válvula antirretorno .....Cod. 02832004 / EAN 8422248480499.....

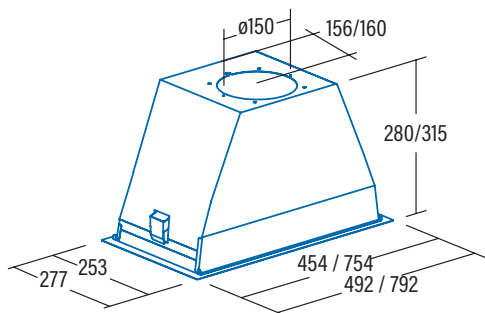

<b>Código</b>	<b>02030305</b>
<b>EAN</b>	<b>8422248077842</b>
<b>Modelo</b>	<b>GL 45 X</b>
<b>Tipo</b>	Grupo filtrante
<b>Ficha de producto según directivas EU65/2014 - EN61591, EN60704-2-13, EN50564</b>	
AEC (Consumo de Energía Anual) (kWh/año)	58,3
EEL class (Clase de Eficiencia Energética)	A
FDE (Eficiencia Fluidodinámica)	30,2
FDE class (Clase de Eficiencia Fluidodinámica)	A
LE (Eficiencia de Iluminación) (lux/W)	24,3
LE class (Clase de Eficiencia de Iluminación)	B
GFE (Eficiencia de Filtrado de Grasa)	91,2
GFE Class (Clase de Eficiencia de Filtrado de Grasa)	B
Flujo de aire en velocidad mínima (m³/h)	340
Flujo de aire en velocidad máxima (m³/h)	600
Flujo de aire en velocidad intensiva (TURBO) (m³/h)	820
Potencia sonora en velocidad mínima (dB)	50
Potencia sonora en velocidad máxima (dB)	65
Potencia sonora en velocidad intensiva (TURBO) (dB)	67
Po (Consumo de Electricidad en modo Desactivado) (W)	0,3
Ps (Consumo de Electricidad en modo de Espera) (W)	0
<b>Directiva Integración según EU 66/2014</b>	
f (Factor de Incremento en el Tiempo)	0,9
EEL (Eficiencia Energética)	54,4
QBEP (Flujo de aire en Punto de Máxima Eficiencia) (m³/h)	429,4
PBEP (Diferencia de Presión Estática en Punto de Máxima Eficiencia) (Pa)	405
WBEP (Potencia Eléctrica de entrada en Punto de Máxima Eficiencia) (W)	159,8
WL (Consumo Nominal de electricidad del sistema de Iluminación de la superficie de cocción) (W)	7
EMIDDLE (Iluminancia media del sistema de iluminación de la superficie de cocción) (lux)	170
<b>Dimensiones exteriores</b>	
Ancho (mm)	492
Fondo (mm)	277
Altura máxima total (mm)	280
Altura mínima total (mm)	280
Diametro de salida (mm)	150/125
<b>Características</b>	
Motor	BT3
Niveles de extracción	3+1
Consumo máximo motor (W)	280
Presión Máxima (Pa)	450
Presión Turbo (Pa)	470
Tipo de control	TC4i
Desconexión automática	√
Indicador electrónico saturación filtro	√
Tipo de filtro	Metálico
Número de filtros antigrasa	2
Interior blindado	-
<b>Iluminación</b>	
Clase de lámparas	EcoLed
Iluminación regulable en intensidad	√
Nº de lámparas	2
<b>Instalación</b>	
Distancia mínima a una placa de cocción eléctrica (mm)	550
Distancia mínima a una placa de cocción de gas (mm)	650
Instalación con salida de aire al exterior / recirculación	AMBAS
Sistema de fácil instalación	√
<b>Conexión eléctrica</b>	
Potencia total de acometida (W)	287
Tensión nominal (V)	220-240
Frecuencia de la red (Hz)	50
Aislamiento eléctrico	CLASE II
Clavija	EU - 2 pins
<b>Accesorios</b>	
Extension tubo superior	-
Tubos decorativos blancos	-
Tubos decorativos negros	-
Embelledor Islas	-
Válvula antirretorno	02832004
Filtro metálico MAX PRO	-
Filtro metálico	02811000
Filtro DUAL (metálico + carbón activo)	02811003
Filtros carbón activo	02859398
Tubo flexible silenciador	02893002

# CAMPANAS

											
TIRA LED REGULABLE	TIRA LED	TIRA LED BICOLOR	ECO LED REGULABLE	ECO LED	LED E-14	LÁMPARAS BAJO CONSUMO 9W	TOUCH CONTROL	PANEL ELECTRÓNICO	PANEL ELECTRÓNICO DISPLAY DIGITAL	PANEL TÁCTIL DISPLAY DIGITAL	PANEL MECÁNICO
											
LIMPIEZA DE FILTROS	FILTROS LAVABLES	ASPIRACIÓN PERIMETRAL	VELOCIDAD EXTRA SILENCIOSA	ANCHO DEL PRODUCTO	SILENT SPLIT TECHNOLOGY	DURALUM ANTIHUELLAS	CONTROL REMOTO	CONECTIVIDAD PRO	CONECTIVIDAD AUTO		

# HORNOS

					
PIRÓLISIS	PRECALENTAMIENTO RÁPIDO 150°C EN 4 MIN	DESCONGELACIÓN	GRILL TOTAL VENTILADO	GRILL VENTILADO	GRILL TOTAL
					
GRILL	COCCIÓN TRADICIONAL VENTILADA	COCCIÓN TRADICIONAL	RESISTENCIA SOLERA	RESISTENCIA SUPERIOR	RESISTENCIA SOLERA VENTILADA
					
SOLERA + TURBO CURCULAR (PIZZA Y PASTELERÍA)	TURBO CIRCULAR	GRILL + RESISTENCIA SOLERA	FUNCIÓN PIZZA	FUNCIÓN ECO	LUZ INTERIOR
					
MANTENER CALIENTE	BAJA TEMPERATURA	HORNOS DE FONDO REDUCIDO 50 cm	HORNOS ANCHURA DE 90 cm	HORNOS ALTURA DE 45 cm	

# PLACAS

			
FUNCIÓN BOOSTER	CONTROL TÁCTIL SLIDER	CONTROL TÁCTIL	NÚMERO DE ZONAS DE COCCIÓN
			
BLOQUEO DE SEGURIDAD	DIÁMETRO MÁXIMO DE LA ZONA DE COCCIÓN	ZONAS MODULARES	COCCIÓN POR TEMPERATURA
			
FUNCIÓNES DE COCCIÓN	TEMPORIZADOR		
			
VÁLVULA DE SEGURIDAD	QUEIMADORES DE HIERRO FUNDIDO	QUEIMADORES ESMALTADOS	

# MENAJE

			
APTO PARA INDUCCIÓN	APTO PARA PLACA ELÉCTRICA	APTO PARA GAS	APTO PARA VITROCERÁMICA

# GAMA BLANCA

			
EXTRA SILENCIOSO	ILUMINACIÓN LED	TERCERA BANDEJA PARA CUBERTERÍA	NOFROST

# CLASIFICACIÓN ENERGÉTICA

			
---	--	---	---