

cata

DECORATIVAS ISLAS



ISLA LEGEND

A+ POWER+ SILENT
motor BRUSHLESS



ISLA LEGEND

Cod. **02097202** EAN **8422248061681**

- Panel de **Control Táctil** con temporizador de desconexión automática e indicador de limpieza de filtros
- 5 niveles de extracción, 4 + 1 **TURBO**
- Capacidad de extracción máxima - mínima (Reg.(UE) nº65/2014): **820m³/h - 200m³/h**
- **Nivel sonoro (Reg.(UE) nº65/2014): 40dB(A)**, máximo: 64dB(A)
- **1ª velocidad modo silencioso**
- Motor Brushless. Extra silencioso. Consumo máximo de energía **130W**
- **Iluminación de alta eficiencia mediante LEDs, regulables en intensidad**
- Sistema de fácil instalación
- Filtros lavables en lavavajillas
- Acabado en inox y **crystal espejo**
- Presión max.: 455 Pa - Presión TURBO: 470 Pa
- Descarga 150/125 mm
- **Clase de eficiencia energética: A+**

► **Accesorios (no incluidos)**

Filtro de Carbón Activo (no incluido).....Cod. 02859398 / EAN 8422248075497.....
Válvula antirretorno (no incluido).....Cod. 02832004 / EAN 8422248480499.....

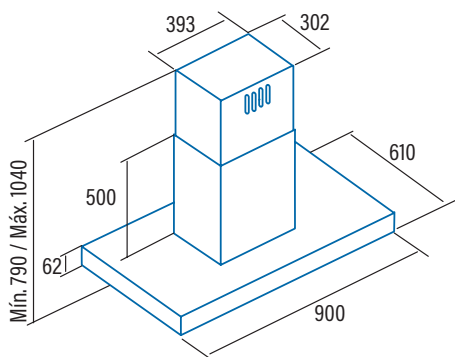

Código	02097202
EAN	8422248061681
Modelo	ISLA LEGEND 900 XGBK
Tipo	Isla
Ficha de producto según directivas EU65/2014 - EN61591, EN60704-2-13, EN50564	
AEC (Consumo de Energía Anual) (kWh/año)	26
EEl class (Clase de Eficiencia Energética)	A+
FDE (Eficiencia Fluidodinámica)	33,1
FDE class (Clase de Eficiencia Fluidodinámica)	A
LE (Eficiencia de Iluminación) (lux/W)	36
LE class (Clase de Eficiencia de Iluminación)	A
GFE (Eficiencia de Filtrado de Grasa)	91,2
GFE Class (Clase de Eficiencia de Filtrado de Grasa)	B
Flujo de aire en velocidad mínima (m³/h)	200
Flujo de aire en velocidad máxima (m³/h)	645
Flujo de aire en velocidad intensiva (TURBO) (m³/h)	820
Potencia sonora en velocidad mínima (dB)	40
Potencia sonora en velocidad máxima (dB)	64
Potencia sonora en velocidad intensiva (TURBO) (dB)	67
Po (Consumo de Electricidad en modo Desactivado) (W)	0,41
Ps (Consumo de Electricidad en modo de Espera) (W)	0
Directiva Integración según EU 66/2014	
f (Factor de Incremento en el Tiempo)	0,8
EEl (Eficiencia Energética)	44,8
QBEP (Flujo de aire en Punto de Máxima Eficiencia) (m³/h)	344,8
PBEP (Diferencia de Presión Estática en Punto de Máxima Eficiencia) (Pa)	244
WBEP (Potencia Eléctrica de entrada en Punto de Máxima Eficiencia) (W)	70,8
WL (Consumo Nominal de electricidad del sistema de Iluminación de la superficie de cocción) (W)	7
EMIDDLE (Iluminancia media del sistema de iluminación de la superficie de cocción) (lux)	252
Dimensiones exteriores	
Ancho (mm)	900
Fondo (mm)	610
Altura máxima total (mm)	1040
Altura mínima total (mm)	790
Diametro de salida (mm)	150/125
Características	
Motor	BTDCA
Niveles de extracción	4 + 1
Consumo máximo motor (W)	130
Presión Máxima (Pa)	455
Presión Turbo (Pa)	470
Tipo de control	TC5i
Desconexión automática	√
Indicador electrónico saturación filtro	√
Tipo de filtro	Metálico
Número de filtros antigrasa	4
Interior blindado	-
Iluminación	
Clase de lámparas	EcoLed
Iluminación regulable en intensidad	√
Nº de lámparas	2
Instalación	
Distancia mínima a una placa de cocción eléctrica (mm)	650
Distancia mínima a una placa de cocción de gas (mm)	650
Instalación con salida de aire al exterior / recirculación	AMBAS
Sistema de fácil instalación	√
Conexión eléctrica	
Potencia total de acometida (W)	137
Tensión nominal (V)	220-240
Frecuencia de la red (Hz)	50
Aislamiento eléctrico	CLASE II
Clavija	EU - 2 pins
Accesorios	
Extension tubo superior	-
Tubos decorativos blancos	-
Tubos decorativos negros	-
Embellecedor islas	02864300
Válvula antirretorno	02832004
Filtro metálico MAX PRO	02800917
Filtro metálico	02800200*
Filtro DUAL (metálico + carbón activo)	02800918
Filtros carbón activo	02859398
Tubo flexible silenciador	02893002

CAMPANAS

											
TIRA LED REGULABLE	TIRA LED	TIRA LED BICOLOR	ECO LED REGULABLE	ECO LED	LED E-14	LÁMPARAS BAJO CONSUMO 9W	TOUCH CONTROL	PANEL ELECTRÓNICO	PANEL ELECTRÓNICO DISPLAY DIGITAL	PANEL TÁCTIL DISPLAY DIGITAL	PANEL MECÁNICO
											
LIMPIEZA DE FILTROS	FILTROS LAVABLES	ASPIRACIÓN PERIMETRAL	VELOCIDAD EXTRA SILENCIOSA	ANCHO DEL PRODUCTO	SILENT SPLIT TECHNOLOGY	DURALUM ANTIHUELLAS	CONTROL REMOTO	CONECTIVIDAD PRO	CONECTIVIDAD AUTO		

HORNOS

					
PIRÓLISIS	PRECALENTAMIENTO RÁPIDO 150°C EN 4 MIN	DESCONGELACIÓN	GRILL TOTAL VENTILADO	GRILL VENTILADO	GRILL TOTAL
					
GRILL	COCCIÓN TRADICIONAL VENTILADA	COCCIÓN TRADICIONAL	RESISTENCIA SOLERA	RESISTENCIA SUPERIOR	RESISTENCIA SOLERA VENTILADA
					
SOLERA + TURBO CURCULAR (PIZZA Y PASTELERÍA)	TURBO CIRCULAR	GRILL + RESISTENCIA SOLERA	FUNCIÓN PIZZA	FUNCIÓN ECO	LUZ INTERIOR
					
MANTENER CALIENTE	BAJA TEMPERATURA	HORNOS DE FONDO REDUCIDO 50 cm	HORNOS ANCHURA DE 90 cm	HORNOS ALTURA DE 45 cm	

PLACAS

			
FUNCIÓN BOOSTER	CONTROL TÁCTIL SLIDER	CONTROL TÁCTIL	NÚMERO DE ZONAS DE COCCIÓN
			
BLOQUEO DE SEGURIDAD	DIÁMETRO MÁXIMO DE LA ZONA DE COCCIÓN	ZONAS MODULARES	COCCIÓN POR TEMPERATURA
			
FUNCIÓNES DE COCCIÓN	TEMPORIZADOR		
			
VÁLVULA DE SEGURIDAD	QUEIMADORES DE HIERRO FUNDIDO	QUEIMADORES ESMALTADOS	

MENAJE

			
APTO PARA INDUCCIÓN	APTO PARA PLACA ELÉCTRICA	APTO PARA GAS	APTO PARA VITROCERÁMICA

GAMA BLANCA

			
EXTRA SILENCIOSO	ILUMINACIÓN LED	TERCERA BANDEJA PARA CUBERTERÍA	NOFROST

CLASIFICACIÓN ENERGÉTICA

			
---	--	---	---